



# THIEL

Model

**PowerPlane™**

*Coherent*

*Source®*

in-wall

loudspeaker

system

## OWNER INFORMATION

Congratulations on your purchase of the THIEL PowerPlane™ in-wall loudspeaker. This fine product is the result of a dedicated effort to provide very accurate and realistic sound reproduction from a versatile, easy-to-place loudspeaker. We have used very high quality components and taken great care in the PowerPlane's construction. Properly installed and used with good associated equipment, the PowerPlane will provide you with a great deal of sonic enjoyment for many years.



Jim Thiel

---

## **SPEAKER PLACEMENT**

The PowerPlane is designed to perform well in a variety of locations throughout the room. It can be mounted in walls, ceilings, or in an enclosed cabinet. Because of the coaxial/coplanar driver mounting, the PowerPlane can be oriented both horizontally or vertically. For optimum performance, the PowerPlane should not be placed very near room corners or where furniture may obstruct the speaker's output.

## **MOUNTING INSTRUCTIONS**

It is important that the PowerPlane be mounted securely to prevent unwanted vibration, therefore mounting only to the wall material, like drywall, is not recommended. The PowerPlane is designed to fit easily into walls with standard 16" stud spacing so that the speaker is ultimately secured to the framing studs. Suggested wall installation instructions for standard walls are shown below. For vertical speaker mounting, adapters can be ordered from THIEL to help secure the speaker to the studs.

### ***HORIZONTAL MOUNTING***

#### **Step One**



Place the provided cutting template on the desired wall position and secure with removable tape. The template has guide marks to assist with leveling.

#### **Step Two**

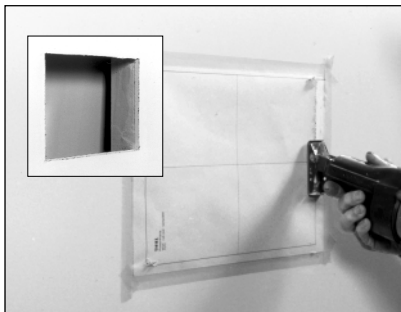

Cut out the wall opening using the template's guide marks.

#### **Step Three**



Place the PowerPlane into the wall opening, level, and secure to the wall studs with the four provided #6 mounting screws.

## VERTICAL MOUNTING

(Step one through four views shown from rear of wall)



Vertical speaker mounting to the frame studs may require using two adjustable mounting adapters (shown at left), available in 16" and 24" lengths. These adapters can be ordered from THIEL.

### Step One



After the wall opening is cut using the template, place the adapter so that the metal side is flush with the bottom of the wall opening. Slide the adjustable metal section so that its metal flange is against the studs. Hammer both sides of the adapter's metal tongs into the studs.

### Step Two



Further secure the adapter by running a screw through the end of the adapter's metal flange into the wall stud. Repeat on the other side.

### Step Three



Once the adapter is mounted, and adjusted, run one screw through the top of the metal piece into the wood below to secure the two adapter pieces together.

### Step Four



Repeat the previous instructions for securing the upper adapter, with the metal side of the adapter flush with the top wall opening. Install the speaker as shown in Step Three of the horizontal mounting.

## CONNECTING THE SPEAKERS

The PowerPlane uses 5-way binding posts which accept several types of speaker cable termination. *Make sure that all connections are tight.* For proper performance, speakers in a multi-speaker system must be wired in the same polarity. The speaker's input terminals are color coded to facilitate this. The wire connected to the red ringed input terminal of each speaker should connect to the respective positive (+) output terminal of the amplifier; the wire connected to the black ringed input terminal should be connected to the respective negative (-) output terminal of the amplifier. The speakers should be connected to the amplifier with high quality cable to ensure minimal loss of power and proper control by the amplifier.

Due to European CE regulations that do not permit banana plug type loudspeaker connections, we ship THIEL speakers with removable plugs installed in the ends of the binding posts. If you wish to use banana plug type connections, you may remove the black plastic plug inserted into the end of each metal binding post cap. To remove the plug, use your fingernail to pry along the bottom edge of the plastic insert and lift out.

## ASSOCIATED EQUIPMENT

The PowerPlane is a very high quality sound reproducer and will benefit from use with high quality associated equipment. Since it is extremely accurate, it will reveal sources of distortion generated elsewhere in the system. For example, distortion resulting from poor recordings or inferior electronics will be reproduced accurately.

## BREAK-IN

The PowerPoint, like most speakers, requires a period of playing before they perform optimally. The time depends on how loudly the speakers are played; more time is required if played softly, less if played loudly. At least 50 hours at moderately loud levels are required before the speaker is performing near optimum.

## POWER REQUIREMENTS

It is important to have enough power to play at the level you desire without distortion. If high sound levels are desired, the PowerPoint's are designed to be used with amplifiers rated up to 200 watts per channel (into 8 ohms). If you play the speakers more loudly than the volume the amplifier can cleanly produce, the amplifier will produce overload (clipping) distortion. The sound will become compressed, strained, and in extreme cases, obviously distorted. This distortion is actually non-musical *additional energy* and since it is concentrated in the high frequency region where the speaker is least able to handle it, tweeters can be damaged in extreme cases.

Keep in mind that sound *quality* is usually much more important than sound *quantity*. There can be large differences in the sonic performance of two amplifiers of equal power, and this is more important than large differences in power. Most everyone will be happier with a 100 watt amplifier of high sonic quality than a 200 watt amplifier of mediocre sonic quality. For this reason, we feel there is no substitute for listening in making your amplifier decision.

The question "how much power do I need?" does not have the simple answer most people expect because it is not determined only by the loudspeaker's efficiency, but also by the volume desired and the size of the room. If all three factors are average, about 100 watts per channel is required. Each factor can raise or lower this amount by about three times.

1) Usually, people who "don't like music loud" can decrease their power to about one-half. Also, people who like music loud should increase their power by 2 times or more. Most people fall within a normal range.

2) A speaker with a low efficiency of 84 dB/W-m will require twice the power of an average 87 dB/W-m speaker and one with a high rating of 90 dB/W-m will require only half the power of an average speaker. The PowerPlane is of above average efficiency (89 dB) and therefore requires less than an average amount of power for average volume levels.

3) A small room will need less power for a given loudness level than a large room. A very small room of 1000 cu ft (11' x 11' with an 8' ceiling) will require about half the power of an average size room. A large room of 6000 cu ft (20' x 30' with a 10' ceiling) will require twice the average power. If the listening room is connected to another room by a large open area, the required power will increase, but not by the amount of the combined room volume. If the room has a "dropped" ceiling with light panels, the ceiling will be almost transparent acoustically and the space above the ceiling should be added. If the panels are heavy they will act as a more normal ceiling.

In conclusion, a person who doesn't like to play music very loudly and has a small room can get quality sound with the PowerPlane with as little as 30 watts whereas a person who sometimes likes to play loudly and has a large room may need 200 watts or more.

## GRILLE

The PowerPoint's grille is magnetically attached to the cabinet and can be removed by gently prying the grille forward. The PowerPlane grille can be made more opaque for visual reasons, but with a small amount of sonic degradation, by adding the included "scrim" to the back of the grille. To install the scrim, first remove the metal grille and apply a coating of spray adhesive to the rear of the grille. After the adhesive becomes tacky, press the scrim to the grille starting at the center and working outward making sure the scrim adheres to the grille everywhere it makes contact.

## PAINTING THE FRONT PANEL

The PowerPlane is shipped with an off-white finish, but can be painted any desired color. To paint the speaker, first remove the grille and then the driver trim ring by removing the six mounting screws. Place the mask over the driver, then place the trim ring on top of the mask. Painting should be done prior to installing the scrim, as mentioned above.



Painting mask placement

## SERVICE

If your speaker system requires service, contact your authorized THIEL dealer. If you need to contact THIEL, service information and technical support is available at (606) 254-9427, Monday-Friday, 8:30 a.m. - 5:00 p.m. Eastern Time, or via e-mail at [service@thielaudio.com](mailto:service@thielaudio.com).

## REPLACING THE COAXIAL TWEETER MODULE



In the unlikely event that your PowerPlane loudspeaker requires service, the entire coaxial driver can be removed from the front of the cabinet, or the tweeter module can be replaced separately without removing the woofer.

To replace just the tweeter module, bend the end of small paper clip and hook it under the module's protective screen. While applying pressure against the screen with two fingers, slowly pull the module out. When installing the new tweeter, position it so that both module pins are placed in the two socket holes of the magnet system. Make sure that the pin marked with a red dot is inserted into the red marked hole. After the new module is inserted, push hard on the screen with some lateral force in all directions to insure that the tweeter is firmly seated and sealed.

## POWERPLANE CABINET DIMENSIONS

*in millimeters and inches*

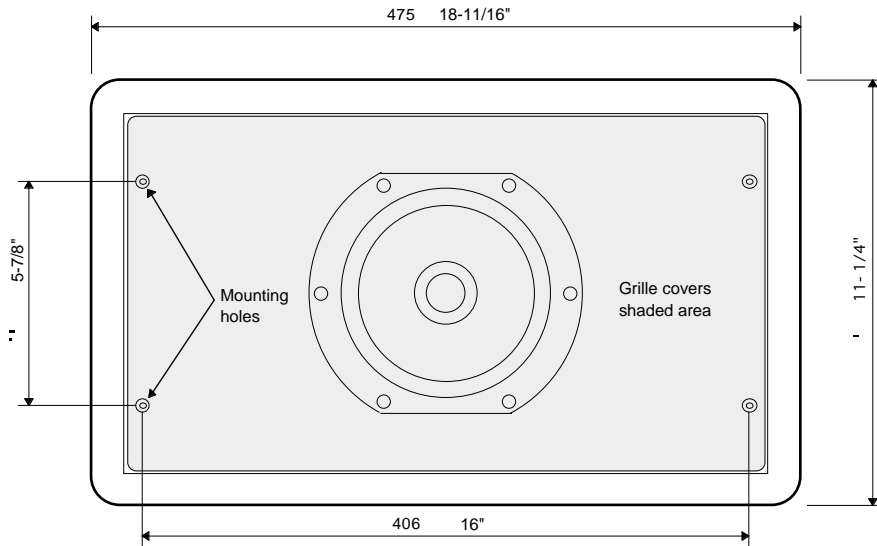

**FRONT VIEW**

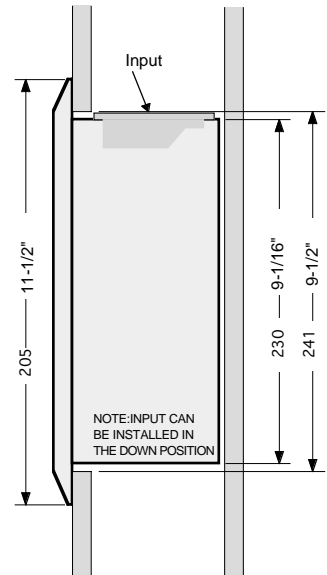

**SIDE VIEW**

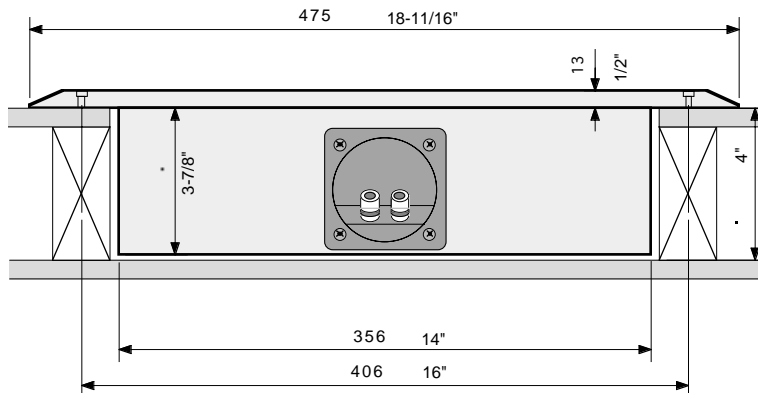

**TOP/BOTTOM VIEW**

**Depth required behind wall surface: 3 7/8"**  
**Required wall opening: 9 1/2" x 14" min.**  
**10 1/2" x 15" max.**

---

## THIEL POWERPLANE SPECIFICATIONS

|                           |                                      |
|---------------------------|--------------------------------------|
| <b>Amplitude Response</b> | 75 Hz-20 kHz $\pm$ 3 dB              |
| <b>Phase Response</b>     | Minimum $\pm$ 10°                    |
| <b>Sensitivity</b>        | 89 dB@2.8 V-1m                       |
| <b>Impedance</b>          | 4 ohms (3 ohms minimum)              |
| <b>Recommended Power</b>  | 30-200 watts                         |
| <b>Size</b>               | 11.5 " H x 4" D x 19" L (horizontal) |
| <b>Weight</b>             | 11 pounds                            |

---

## LIMITED 10 YEAR WARRANTY

THIEL warrants every THIEL PowerPlane system against defects in materials and workmanship to the original owner for a period of ten years from the date of purchase. THIEL will, at no charge, replace any defective part and make any repairs necessary to ensure its proper performance when the defective unit is returned to us postpaid.

This warranty does not cover damage due to accident or abuse and is void if the unit has been tampered with.

This warranty is automatic and no registration is required. This warranty gives you specific legal rights. You may also have other rights which are particular to your state.

The following information is for your records.

Serial Numbers \_\_\_\_\_

Purchase Date \_\_\_\_\_

Purchased From \_\_\_\_\_

---



## THIEL

1026 Nandino Boulevard  
Lexington, Kentucky 40511-1207

Telephone: 859-254-9427 • E-mail: [mail@thielaudio.com](mailto:mail@thielaudio.com) • Web: [www.thielaudio.com](http://www.thielaudio.com)